

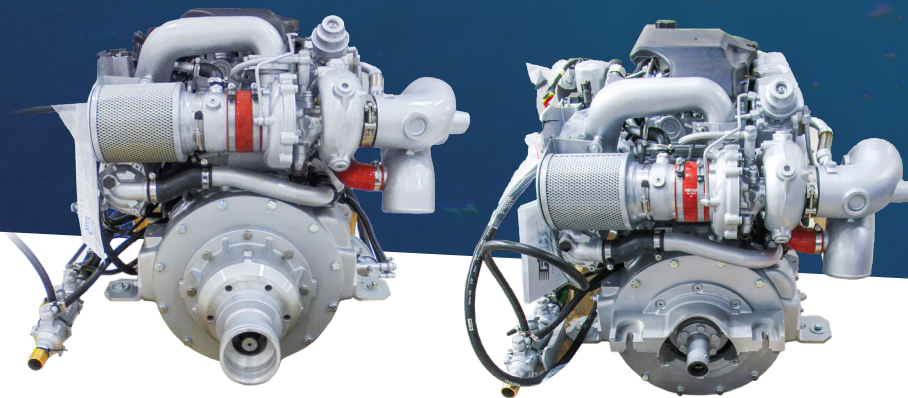

MARINE DIESEL ENGINES



IN/OUTBOARD MARINE ENGINE **30HPEP**

**READY TO FIT ALL
VOLVO STERNDRIVES**

Models:
30HPEP 270 - 30HPEP 250
30HPEP 225 - 30HPEP 180

FNM@ 30HPEP engine is based on the tested FPT 30 4-cylinder Common Rail engine. This marine engine uses a common-rail fuel injection system controlled by an ECU specifically made for it. The result is a high power-to-displacement ratio unit.

Dimensions | FNM 30HPEP ready to fit to Volvo 290 Sterndrive

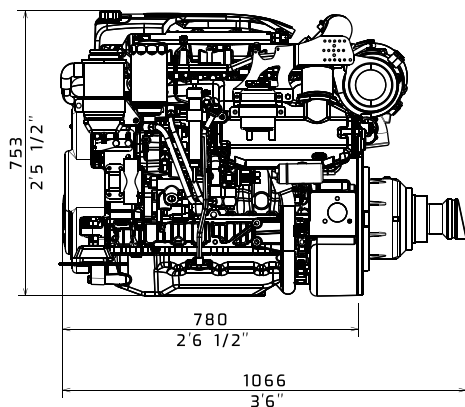

Starboard Side
Lato Sinistro

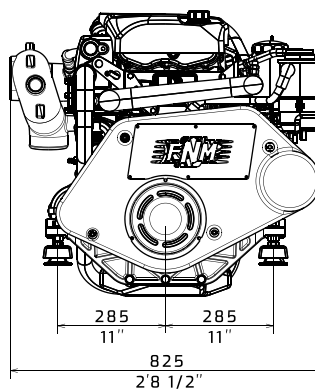

Front View
Vista Frontale

Technical data

Engine model	30 HPEP 270	30 HPEP 250	30 HPEP 225	30 HPEP 180
Max Power	198,5 kW 270 HP 4100 rpm	184 kW 250 HP 4100 rpm	165 kW 225 HP 4100 rpm	132 kW 180 HP 3800 rpm
Max Torque	560 Nm 2600 rpm	553 Nm 2600 rpm	520 Nm 2300 rpm	N.D.
Number of cylinders	4 in line			
Displacement (l) - (cc)	3 - 2.988			
Bore and Stroke (mm) - (in)	[95,8x104] - (3,77x4,09)			
Dry weight (kg)	330			
Cooling	Water			
Combustion	Direct Injection Common Rail			
Induction	Turbocharged and intercooled			
Emission compliance	Directive 2013/53/UE			

Technical data according to ISO8665. Fuel complies EN590. Merchant fuel may differ in specification and may influence engine power output and consumption. Production tolerance within 5% (of power). Not all models, standard equipment and accessories are available in all countries. All specifications are subject to change without notice.

Standard technical equipment

ENGINE BLOCK AND HEAD

- Cylinder block made of cast-iron
- Cylinder head made of aluminium
- 4-valve per cylinder technology with hydraulic lash adjusters
- Double overhead camshafts
- Automotive-class availability of service and parts
- Metal chain gear

ENGINE MOUNTING

- Flexible engine mounting

LUBRICATION SYSTEM

- Easily replaceable oil filter, on top of engine
- Easily to inspect or replace oil separator
- Double oil vapour filter technology
- Integrated cooler with engine's coolant

FUEL SYSTEM

- Common rail fuel injection system
- CMD proprietary ECU
- Fuel filter with water separator and alarm

AIR INLET AND EXHAUST SYSTEM

- Commercial-grade air filter
- Oil vapours vented into inlet air
- Exhaust elbow or raiser depending on application
- Coolant-cooled turbocharger
- Raw-water cooled intercooler

COOLING SYSTEM

- Thermostatically regulated freshwater cooling
- Thermal unit that integrates tubular heat exchanger and expansion tank
- Easily accessible seawater impeller pump

ELECTRICAL SYSTEM

- 12V standard electrical system
- 12V-1,8kW starter
- Alternator 12V-140A
- Emergency stop button on engine's ECU
- CANBUS Panel with 8m extension and digital display of engine data

Optionals

- Boiler kit for heating
- Various length panel extension
- Second control panel for flybridge installations
- RACOR and Mediterraneo filters
- Additional PTO (ISO4183 Z/SPZ)
- Steering pump
- NMEA2000 compatibility kit
- Engine Ready to fit to Volvo SX and DPS Stern Drive
- 12V two-pole electrical system

Performance curves

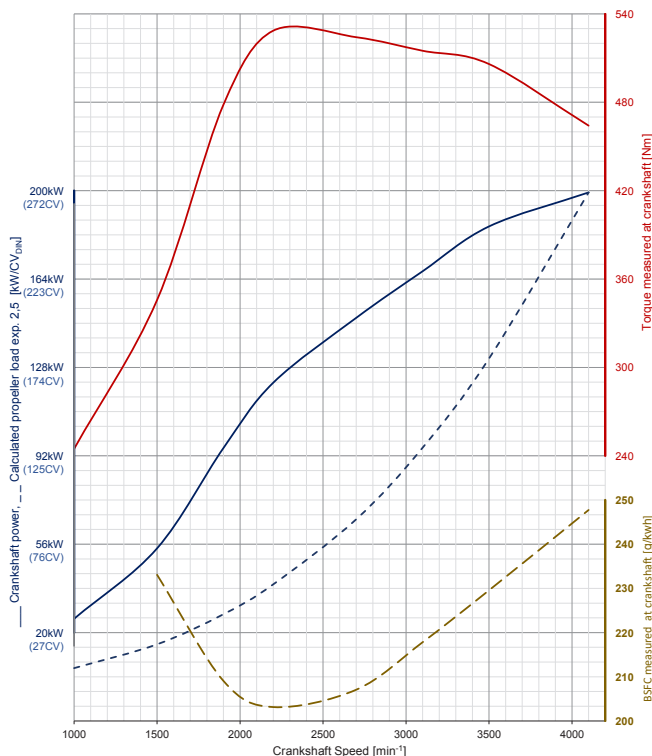

Referred to **30HPE 270**

Panel instrument CANBUS

Panel Instrument **high brightness 5" TFT display**, with **touchscreen** and a very simple and intuitive interface.

- Engine data acquisition with CANBUS J1939 interface.
- Data acquisition from traditional sensors for up to eight analog inputs, five digital inputs and one frequency input
- Acquisition of navigation data with NMEA0183 interface
- Up to five relay command outputs for signals and simple activations
- Alarm monitoring according to approved safety standards
- Automatic brightness adjustment and day / night mode
- USB local connectivity for firmware update and configuration

The unit is supplied already programmed and ready to work.

